

## TT WireWasher

The **TT WireWasher** is used to obtain an efficient removal of ashes, inks, glues and fines by means of stock washing and consequent thickening. The **TT WireWasher** is driven by a variable speed motor, designed to operate also at high speed, and the wire run is complete of all the necessary accessories to optimize the unit operation.

The stock is thickened and washed

thanks to the centrifugal and draining effect and is collected in a hopper or chest from where, once diluted, is sent to the following treatment stages. The recovered water, rich of contaminants, is collected in a water tank and sent to the clarification. The frame is in cantilever in order to reduce as much as possible the downtime for wire change and all the components in contact with stock and

water are manufactured in stainless steel. With its range of working widths, the **TT WireWasher** family can be utilized in various applications in terms of stock cleanliness and hydraulic capacity.

Furthermore its compact and easy installation allows to introduce this unit in existing stock preparation plants.

### PULP THICKENING AREA

- High speed
- Compact & Easy Installation

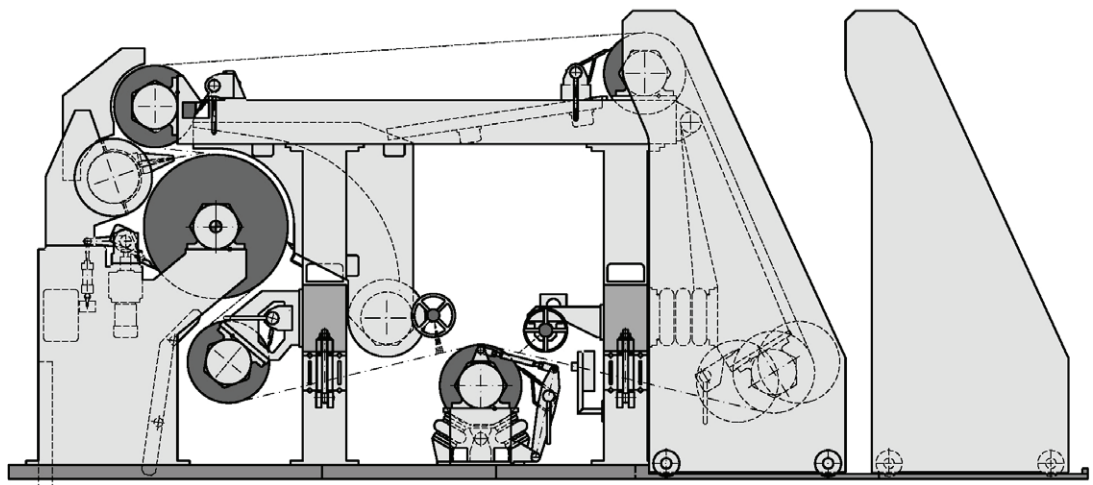

Model	CW 1	CW 2	CW 3
Working speed (m/min)	350-800	350-800	350-800
Max hydraulic capacity (l/min)	6800	10400	12800
Inlet consistency (%)	0.7-1.5	0.7-1.5	0.7-1.5
Outlet consistency (%)	6-10	6-10	6-10
Installed power (kW)	30	45	55

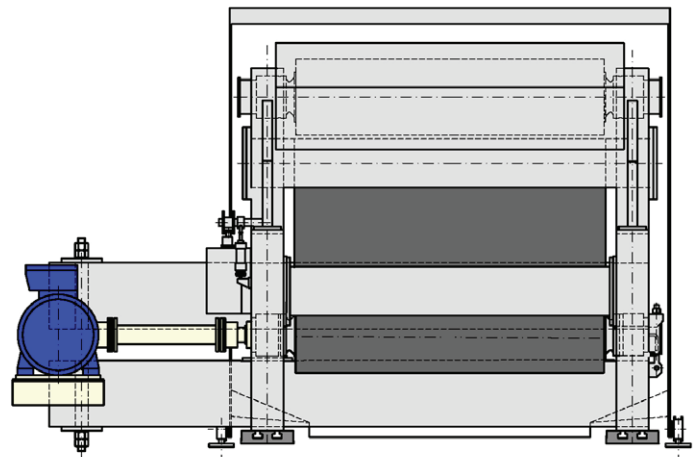

For more information:

[info@toscotec.com](mailto:info@toscotec.com), [www.toscotec.com/products](http://www.toscotec.com/products)

Specifications in this document are subject to change without notice. Product names in this publication are all trademarks of Toscotec S.p.A.

[www.toscotec.com](http://www.toscotec.com)